

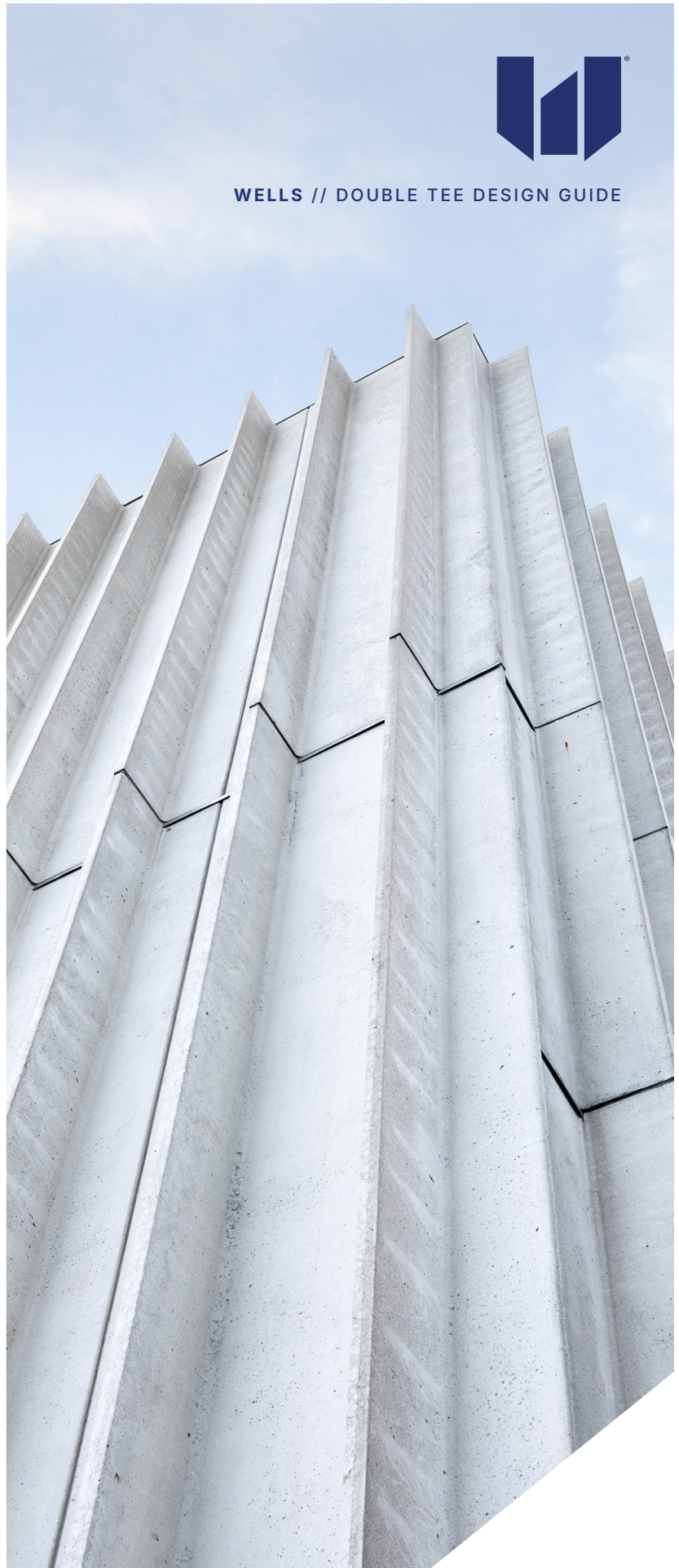

WELLS // DOUBLE TEE DESIGN GUIDE

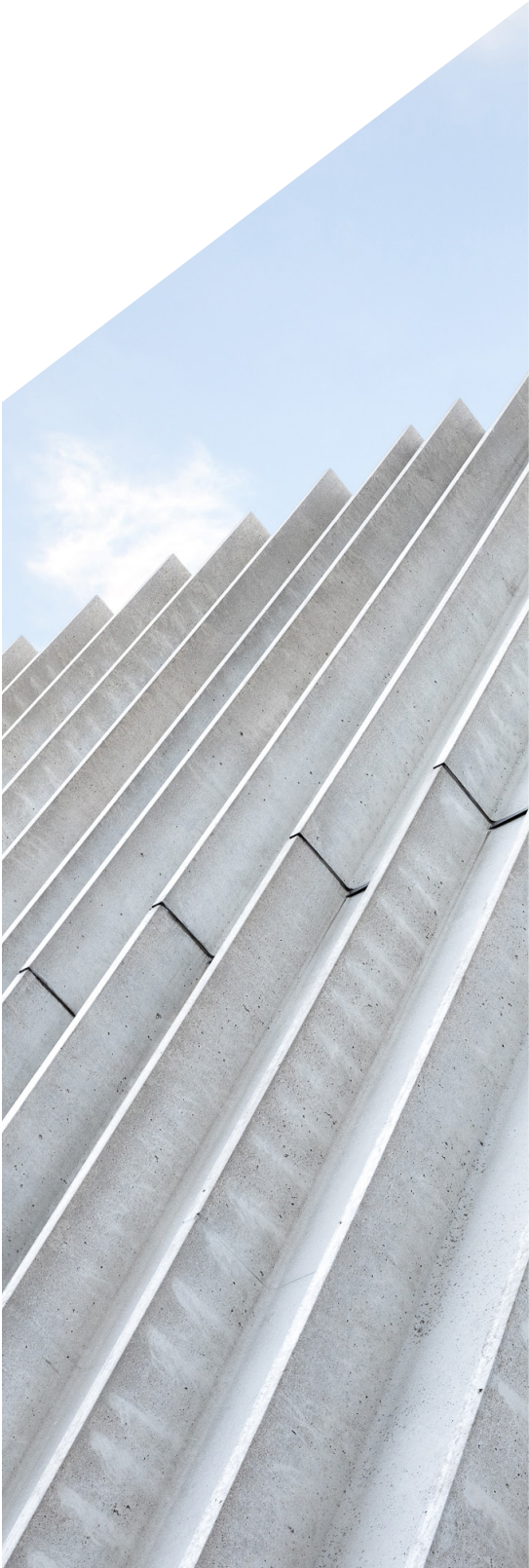



## CONTENTS

- 03 Common uses for Double Tees
- 04 Common Tee Sections
- 08 Composite Section Options
- 09 Sound Transmission
- 10 Determining the Fire Rating
- 12 Penetrations + Fastenings
- 13 Recommended Connection Details
- 16 Connection of Other Materials

# PRACTICAL FRAMEWORK FOR SUCCESSFUL DESIGN.

Double tees are precast structural systems typically used as framing to achieve long spans. Double tees are used for a variety of building types — from highly loaded structures with assembly or storage loads to lightly loaded roofs with over 100 ft spans. The prestressing steel incorporated during manufacturing of the double tee results in increased durability and longevity over the lifetime of the structure.



### COMMON USES FOR DOUBLE TEES

Double tees are a versatile precast structural system, known for long spans, faster construction, and adaptability across a wide range of performance needs. From durability and resilience to flexibility and efficiency, double tees provide proven strength and reliability for diverse building types and project demands.

- Auditoriums
- Fire Stations
- Food Processing
- Gymnasiums
- Livestock
- Manufacturing
- Medical
- Mission Critical
- Mixed Use
- Natatoriums
- Offices
- Parking
- Residential
- WWTP + WTP



—

Each double tee capacity is determined based on length and thickness of the tee. Contact your local sales rep for exact cross sections used in your project area.

## Common Double Tee Sections

The design information below is intended to introduce designers to a range of common applications of double tees. The spans, building types and loads below can vary widely beyond the listed values. Additional double tee sections exist and can be selected with with proper coordination with Wells Engineering and Preconstruction teams.

### 20" Deep x 10'-0" Wide Nominal

5.5.7.2 DT210 (DT1, DT10)

#### Section Properties

Area .....	395 in <sup>2</sup>
I.....	12,530 in <sup>4</sup>
Yb.....	15.33 in
Yt.....	4.67 in
Sb.....	817 in <sup>3</sup>
St.....	2683 in <sup>3</sup>
Vol./Surf.....	1.28 in
DL.....	42.5 psf
Weight 155pcf.....	425 plf

Design Information	Office Loading	Parking Garage Loading	Roof Loading
Superimposed dead load (psf <sup>1</sup> )	15	5	15
Live load (psf <sup>1</sup> )	100	55 <sup>2</sup>	30
Topping thickness <sup>3</sup> (inches)	4	3	0
Span <sup>1</sup> (feet)	37	45	50
<b>Note 1:</b> Actual maximum span can be adjusted based on a number of considerations, contact Wells for more information			
<b>Note 2:</b> 55 psf accounts for combination case of 30 psf snow and 40 psf live			
<b>Note 3:</b> Tees can also be pretopped and all subsequent loads/spans do not change			
<b>Note 4:</b> psf stands for "pounds per square foot"			

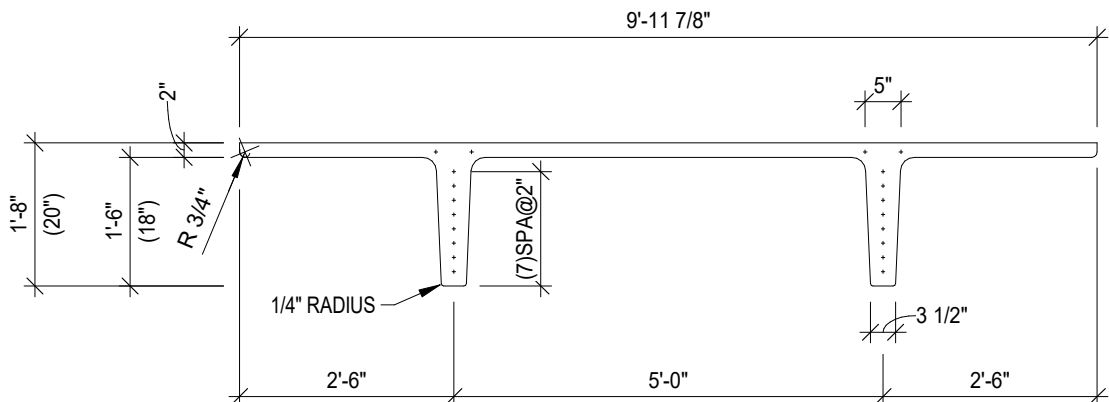

## 24" Deep x 10'-0" Wide Nominal

### 5.5.7.3 DT2410 (DT2, DT3, DT4, DT8)

#### Section Properties

Area .....	461 in <sup>2</sup>
I.....	23,370 in <sup>4</sup>
Yb.....	17.62 in
Yt.....	6.38 in
Sb.....	1326 in <sup>3</sup>
St.....	3663 in <sup>3</sup>
Vol./Surf.....	1.43 in
DL 155pcf.....	49.6 psf
Weight 155pcf.....	496 plf
DL 135pcf.....	43.2 psf
Weight 135pcf.....	432 plf
DL 120pcf.....	38.4 psf
Weight 120pcf.....	384 plf

Design Information	Office Loading	Parking Garage Loading	Roof Loading
Superimposed dead load (psf <sup>1</sup> )	15	5	15
Live load (psf <sup>1</sup> )	100	55 <sup>2</sup>	30
Topping thickness <sup>3</sup> (inches)	4	3	0
Span <sup>1</sup> (feet)	50	60	65
<b>Note 1:</b> Actual maximum span can be adjusted based on a number of considerations, contact Wells for more information			
<b>Note 2:</b> 55 psf accounts for combination case of 30 psf snow and 40 psf live			
<b>Note 3:</b> Tees can also be pretopped and all subsequent loads/spans do not change			
<b>Note 4:</b> psf stands for "pounds per square foot"			

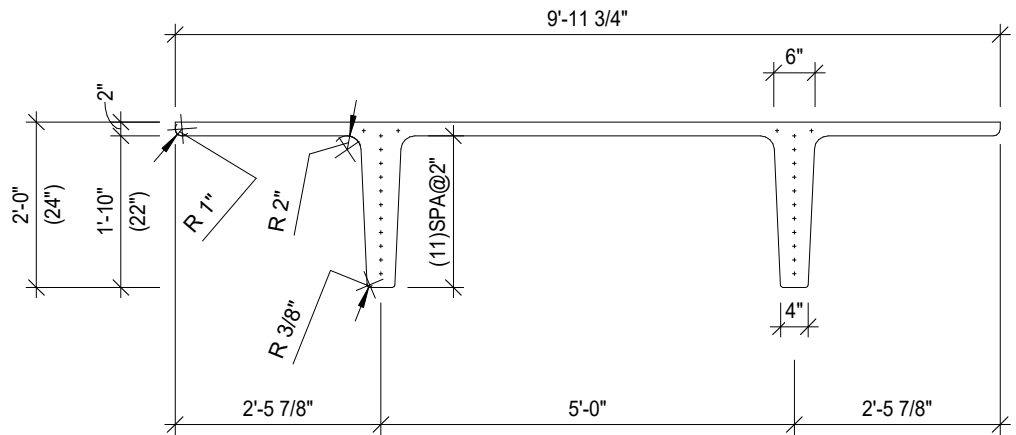

## 26" Deep x 12'-0" Wide Nominal

### 5.5.7.4 DT2612 (DT5, DT7, DT11)

#### Section Properties

Area .....	640 in <sup>2</sup>
I.....	40,346 in <sup>4</sup>
Yb.....	18.42 in
Yt.....	7.58 in
Sb.....	2190 in <sup>3</sup>
St.....	5323 in <sup>3</sup>
Vol./Surf.....	1.71 in
DL.....	57.4 psf
Weight 155pcf.....	689 plf

Design Information	Office Loading	Parking Garage Loading	Roof Loading
Superimposed dead load (psf <sup>1</sup> )	15	5	15
Live load (psf <sup>1</sup> )	100	55 <sup>2</sup>	30
Topping thickness <sup>3</sup> (inches)	4	3	0
Span <sup>1</sup> (feet)	50	60	65
<b>Note 1:</b> Actual maximum span can be adjusted based on a number of considerations, contact Wells for more information			
<b>Note 2:</b> 55 psf accounts for combination case of 30 psf snow and 40 psf live			
<b>Note 3:</b> Tees can also be pretopped and all subsequent loads/spans do not change			
<b>Note 4:</b> psf stands for "pounds per square foot"			

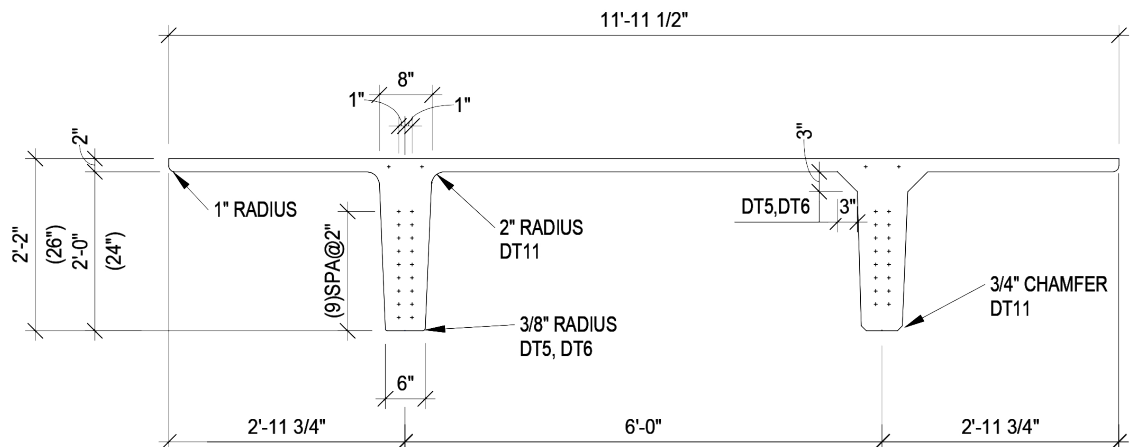

## 28" Deep x 12'-0" Wide Nominal

### 5.5.7.5 DT2812 (E-2)

#### Section Properties

Area .....	641.8 in <sup>2</sup>
I.....	48,348 in <sup>4</sup>
Yb.....	19.6 in
Yt.....	8.4 in
Sb.....	2,471 in <sup>3</sup>
St.....	5,767 in <sup>3</sup>
DL.....	57.5 psf
Weight 155pcf.....	690.8 plf

Design Information	Office Loading	Parking Garage Loading	Roof Loading
Superimposed dead load (psf <sup>1</sup> )	15	5	15
Live load (psf <sup>2</sup> )	100	55 <sup>2</sup>	30
Topping thickness <sup>3</sup> (inches)	4	3	0
Span <sup>1</sup> (feet)	52	63	70
<b>Note 1:</b> Actual maximum span can be adjusted based on a number of considerations, contact Wells for more information			
<b>Note 2:</b> 55 psf accounts for combination case of 30 psf snow and 40 psf live			
<b>Note 3:</b> Tees can also be pretopped and all subsequent loads/spans do not change			
<b>Note 4:</b> psf stands for "pounds per square foot"			

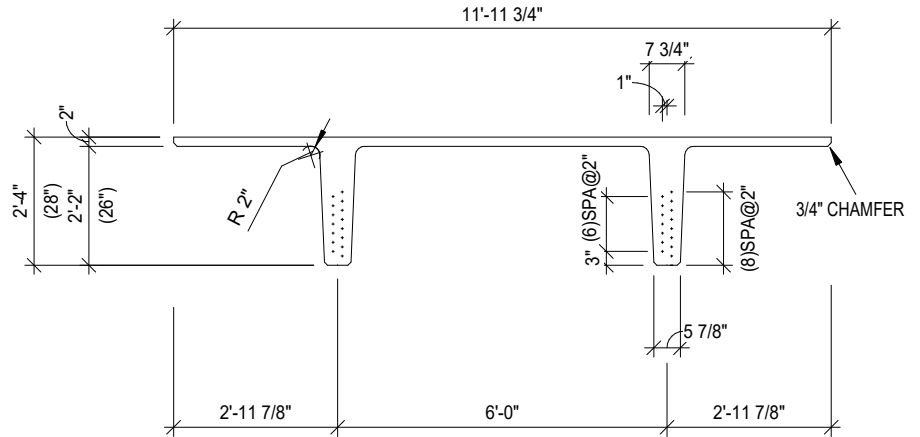

## 30" Deep x 16'-0" Wide Nominal

### 5.5.7.6 DT6016 (E-4)

#### Section Properties

Area .....	1,118 in <sup>2</sup>
I.....	69,108 in <sup>4</sup>
Yb.....	23.54 in
Yt.....	6.46 in
Sb.....	2,915 in <sup>3</sup>
St.....	10,702 in <sup>3</sup>
DL.....	75.2 psf
Weight 155pcf.....	1,118 plf

Design Information	Office Loading	Parking Garage Loading	Roof Loading
Superimposed dead load (psf <sup>3</sup> )	15	5	15
Live load (psf <sup>3</sup> )	100	55 <sup>2</sup>	30
Span <sup>1</sup> (feet)	45	60	67
<b>Note 1:</b> Actual maximum span can be adjusted based on a number of considerations, contact Wells for more information			
<b>Note 2:</b> 55 psf accounts for combination case of 30 psf snow and 40 psf live			
<b>Note 3:</b> psf stands for "pounds per square foot"			

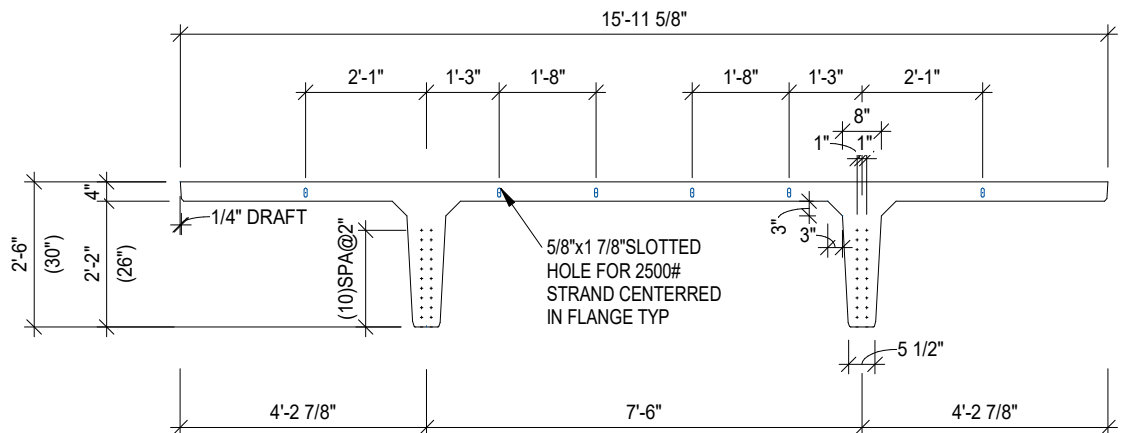

**NOTE: THIS IS AN EXAMPLE OF A PRETOPPED DOUBLE TEE. THE FLANGE THICKNESS CAN BE INCREASED TO ACHIEVE A DESIRED FIRE RATING AS NEEDED.**

# 32" Wide x 10'0" Wide Nominal

5.5.7.7 DT3210 (DT4, DT16, DT9)

## Section Properties

Area .....	609 in <sup>2</sup>
I.....	59,354 in <sup>4</sup>
Yb.....	22.03 in
Yt.....	9.98 in
Sb.....	2695 in <sup>3</sup>
St.....	5948 in <sup>3</sup>
Vol./Surf.....	1.72 in
DL.....	65.6 psf
Weight 155pcf.....	656 plf

Design Information	Office Loading	Parking Garage Loading	Roof Loading
Superimposed dead load (psf <sup>1</sup> )	15	5	15
Live load (psf <sup>1</sup> )	100	55 <sup>2</sup>	30
Topping thickness <sup>3</sup> (inches)	4	3	0
Span <sup>1</sup> (feet)	60 <sup>2</sup>	70	85
<b>Note 1:</b> Actual maximum span can be adjusted based on a number of considerations, contact Wells for more information			
<b>Note 2:</b> Vibration should be considered in this application			
<b>Note 3:</b> Tees can also be pretopped and all subsequent loads/spans do not change			
<b>Note 4:</b> psf stands for "pounds per square foot"			

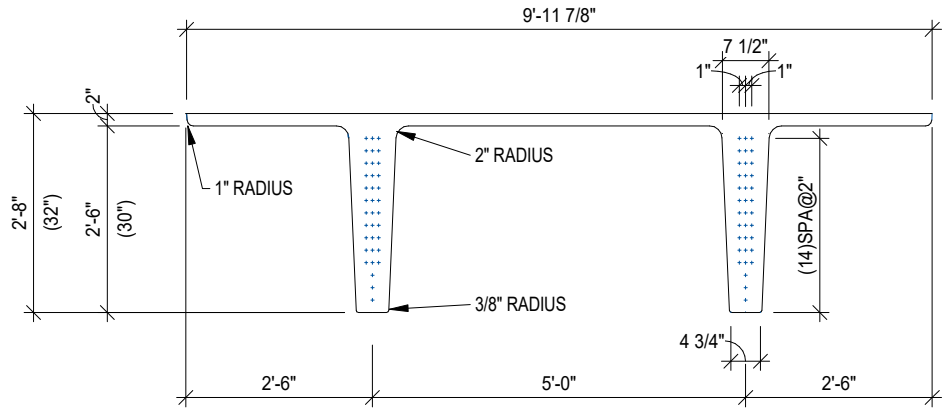

# 42" Deep x 8'-0" Wide Nominal

5.5.7.8 DT4208 (DT9)

## Section Properties

Area .....	624 in <sup>2</sup>
I.....	105,687 in <sup>4</sup>
Yb.....	27.70 in
Yt.....	14.31 in
Sb.....	3817 in <sup>3</sup>
St.....	7388 in <sup>3</sup>
Vol./Surf.....	1.81 in
Weight 155pcf.....	671 plf
DL 155 pcf.....	83.9 psf
Weight 135pcf.....	584 plf
DL 135 pcf.....	73.1 psf
Weight 120pcf.....	520 plf
DL 120pcf.....	65 psf

Design Information	Office Loading <sup>2</sup>	Parking Garage Loading <sup>2</sup>	Roof Loading
Superimposed dead load (psf <sup>1</sup> )	15	5	15
Live load (psf <sup>1</sup> )	100	55 <sup>2</sup>	30
Topping thickness <sup>3</sup> (inches)	4	3	0
Span <sup>1</sup> (feet)	75	90	105
<b>Note 1:</b> Actual maximum span can be adjusted based on a number of considerations, contact Wells for more information			
<b>Note 2:</b> If you wish to use this member size in these structures, contact Wells for more information			
<b>Note 3:</b> Tees can also be pretopped and all subsequent loads/spans do not change			
<b>Note 4:</b> psf stands for "pounds per square foot"			

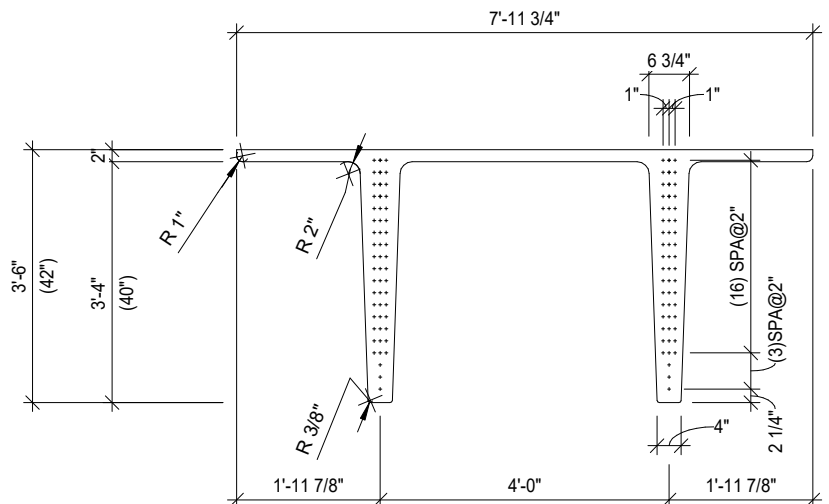



Swedish Medical Center Parking Garage  
Denver, CO  
System: Architectural, Structural



HealthPartners Parking Ramp  
Bloomington, MN  
System: Architectural, Structural



## Composite Section Options

### FIELD-TOPPED

In many areas throughout the country it is common to cast the double tee in an off-site manufacturing facility and then apply a post-pour topping on-site once it is erected. The top flange of the building component is produced with a thickness between 2 to 3 inches. A roughened surface is provided at the interface of the top deck surface and the cast in place topping.

Once the topping cures it increases the overall performance and strength of the double tee. Control joints are also placed in the topping at the joint between components. Topping is usually used as a leveling compound to mitigate the effect of camber.

### PRE-TOPPED

The other option is to simply cast a thickened flange when producing the double tee. This eliminates a significant amount of coordination time needed in post-pour applications. In cold weather climates in particular this option offers cost benefits and a more efficient build. The performance of the double tee is similar to the post-pour method and is easily accommodated in the design of the tee. Pre-topped systems are based on weight limitations, and for longer span double tees, pre-topped may not be the best solution due to weight and length.



# Sound Transmission

Often, acoustical control is specified as to the minimum insulation values of the dividing partition system. Local building codes, lending institutions, and the Department of Housing and Urban Development (HUD) list both airborne STC and impact IIC values for different living environments. For example, the HUD recommendations are given in Table 11.2.2.

Other community ordinances are more specific, listing the sound insulation criteria with relation to particular ambient environments.

Once the objectives are established, the designer should refer to available data, for example, Table 11.2.4, and select the system that best meets these requirements. In this respect, concrete systems have superior properties and can, with minimal effort, comply with these criteria.

*PCI Design Handbook (8th Edition)*

**Table 11.2.2** HUD recommendations for sound transmission class (STC and impact Insulation class (IIC).

Location	STC	IIC
Between living units	45	45
Between living units and public space	50	50

**Table 11.2.4** Airborne sound transmission class (STC) and impact insulation class (IIC) ratings from test of precast concrete assemblies.

Assembly	Description	STC	IIC
<b>Floor-ceiling systems</b>			
20	5-in.-thick flat slabs, 60 lb/ft <sup>2</sup>	52 <sup>a</sup>	24
21	5-in.-thick flat slab concrete with carpet and pad, 61 lb/ft <sup>2</sup>	52 <sup>a</sup>	68
22	6-in.-thick flat slabs, 75 lb/ft <sup>2</sup>	55	34



Precast concrete offers exceptional fire resistance as opposed to wood building materials, providing critical protection by maintaining structural integrity and preventing the spread of flames, making it a reliable choice for safety in building design.

## Determining the Fire Rating

The fire rating of double tees is established based on two principles. The overall flange thickness must be established and sufficient concrete cover must be provided around the prestressed strand.

### FLANGE THICKNESS

The thickness of the double tee deck (floor surface) is chosen in a similar fashion to wall panels or flat slabs. Table 720.1(3) is shown on the next page as defined in the IBC. Aggregate type has a significant impact on the overall rating of the deck and can vary by region.

### CONCRETE COVER

The protection of the prestressed strand within the concrete also impacts the overall fire rating of the member. In the event of a fire, steel reinforcing has a tendency to lose strength through relaxation when subjected to rising temperatures. The concrete acts as an insulator to delay this relaxation, and double tees can be designed to provide an average cover for strand that satisfies the fire rating for the structure. Table 720.1(1) from the IBC is shown on the next page. Note that this specified cover distance relates to the centroid of all the strands in a double tee stem, not the bottom-most strand.



# Procedure for Determining Fire Rating

## FIRE SEPARATION (FLANGE THICKNESS):

1. Table 721.1(3) International Building Code, Item #1 – Siliceous Aggregate 1-1.1 – Slabs

Use the below table to figure out how thick the composite slab must be for a given fire rating.

**TABLE 721.1(3) MINIMUM PROTECTION FOR FLOOR AND ROOF SYSTEMS<sup>a, q</sup>**

FLOOR OR ROOF CONSTRUCTION	ITEM NUMBER	CEILING CONSTRUCTION	THICKNESS OF FLOOR OR ROOF SLAB (inches)				MINIMUM THICKNESS OF CEILING (inches)			
			4 hours	3 hours	2 hours	1 hour	4 hours	3 hours	2 hours	1 hour
1. Siliceous aggregate concrete	1-1.1	Slab (ceiling not required). Minimum cover over nonprestressed reinforcement shall be not less than 3/4". <sup>b</sup>	7.0	6.2	5.0	3.5	—	—	—	—
2. Carbonate aggregate concrete	2-1.1		6.6	5.7	4.6	3.2	—	—	—	—
3. Sand-lightweight concrete	3-1.1		5.4	4.6	3.8	2.7	—	—	—	—
4. Lightweight concrete	4-1.1		5.1	4.4	3.6	2.5	—	—	—	—

## FIRE ENDURANCE (STEEL PROTECTION):

1. Table 721.1(1) International Building Code, Item #3 – 3-1.1 – Bonded Prestensioned Beam

Use the below table to figure out how much cover on strand there needs to be for given rating. Note that the cover is at the centroid of all the strands, not at the bottom-most strand.

**TABLE 721.1(1) MINIMUM PROTECTION OF STRUCTURAL PARTS BASED ON TIME PERIODS FOR VARIOUS NONCOMBUSTIBLE INSULATING MATERIALS<sup>m</sup>**

STRUCTURAL PARTS TO BE PROTECTED	ITEM NUMBER	INSULATING MATERIAL USED	MINIMUM THICKNESS OF INSULATING MATERIAL FOR THE FOLLOWING FIRE-RESISTANCE PERIODS (inches)			
			4 hours	3 hours	2 hours	1 hour
3. Bonded prestensioned reinforcement in prestressed concrete <sup>e</sup>	3-1.1	Carbonate, lightweight, sand-lightweight and siliceous <sup>f</sup> aggregate concrete				
		Beams or girders	4 <sup>g</sup>	3 <sup>g</sup>	2 1/2	1 1/2
		Solid <sup>h</sup>		2	1 1/2	1

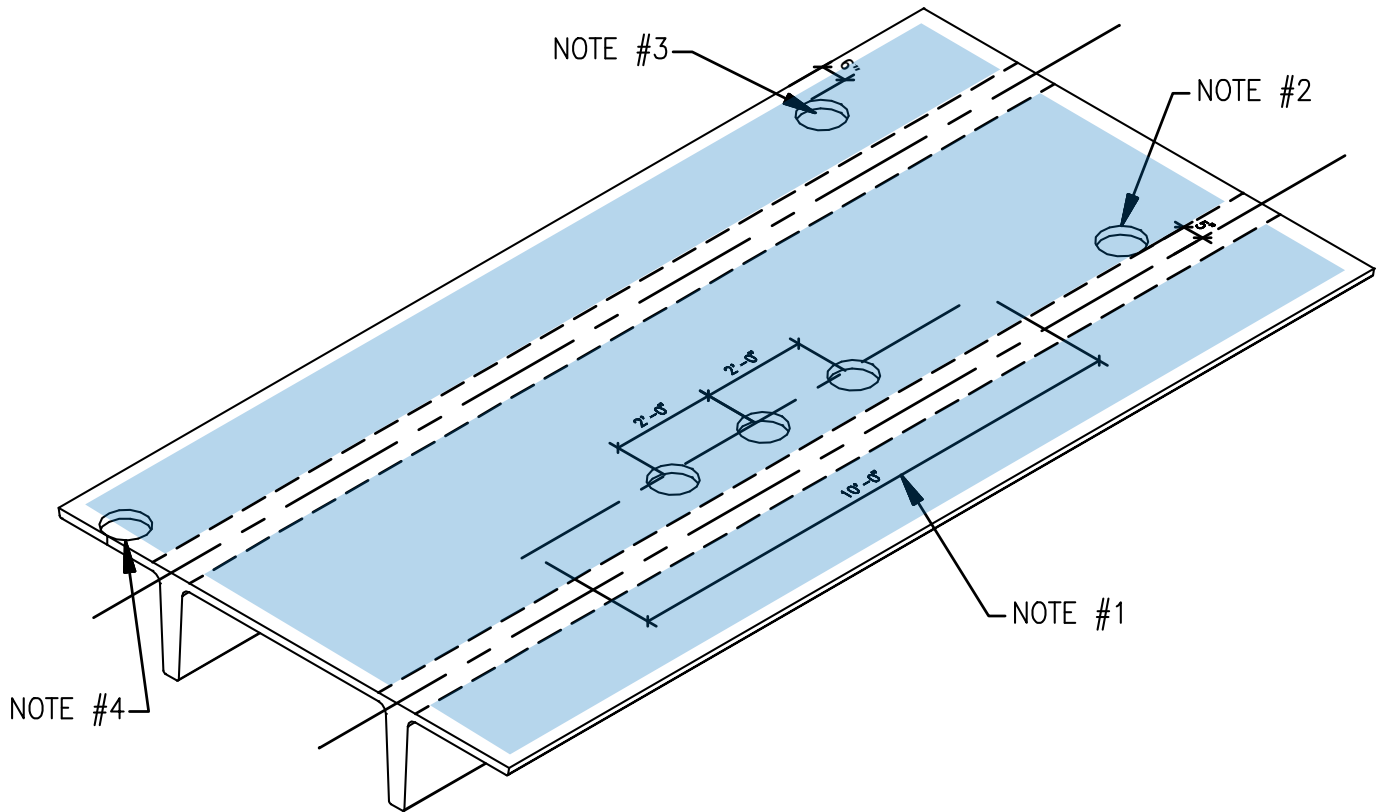

## Field Cut Penetrations

### WHAT TO CONSIDER

Double tees (DT) provide a lot of flexibility with penetrations and fastening, and it is common and acceptable to have large openings in the flange, per shaded regions in the graphic above. The guidelines on this page are intended to provide a rule of thumb for locating openings, and you can contact Wells to coordinate unique conditions. Also reference the Design Handbook on the Wells website for more information.

### CORED HOLES CRITERIA

1. No more than 3 holes in 10 ft in the same line, and not less than 2'- 0" on center between them.
2. Edge of holes cannot be closer than 5" to center of DT stem.
3. Edge of holes must be at least 6" away from edge of DT flange along the edges parallel to legs.
4. Edge of holes could be flush with edge of flange at the ends of DT.
5. Cores must be at least 1'- 0" away in any direction from connections (tee to tee, tee to wall or spandrel, tee to beam).
6. Cored holes with diameters greater than 8" should be coordinated with Wells.
7. Cored holes with spacing less than 2 times the diameter of the hole require coordination with Wells.



# Recommended Connection Details

## DOUBLE TEE BEARING AT BEAM

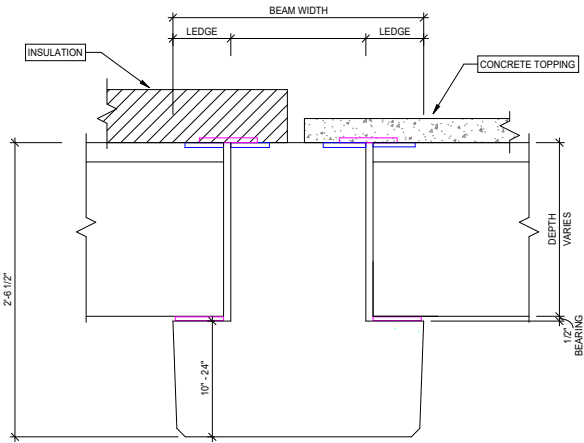

## DOUBLE TEE DAP BEARING AT BEAM

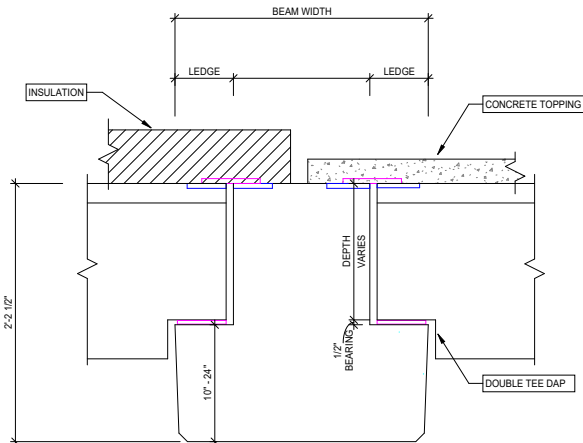

## STEM INSERT FOR MECHANICAL CONDUIT

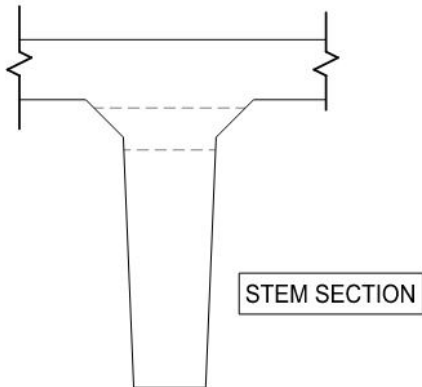
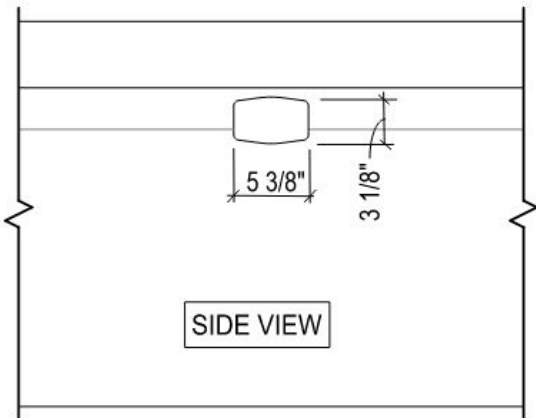

# Recommended Connection Details

**DOUBLE TEE BEARING AT STEEL BEAM**

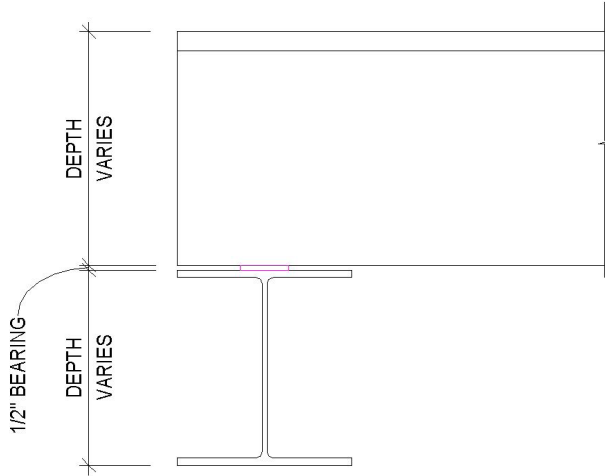

**DOUBLE TEE BEARING AT CMU WALL SLIP**

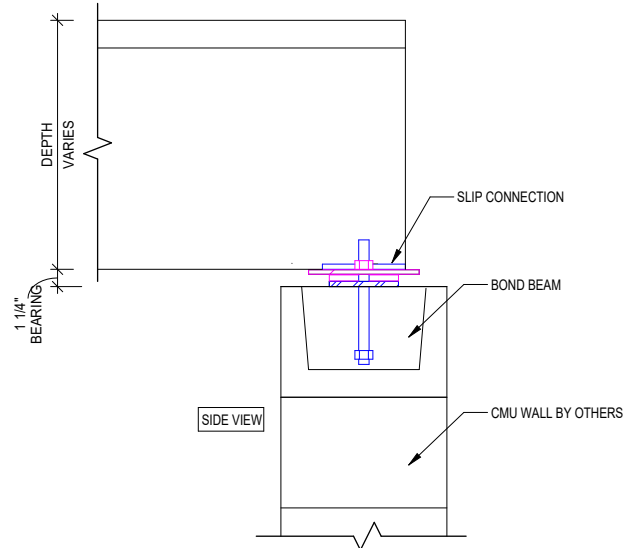

**DOUBLE TEE BEARING ON WALL HAUNCH**

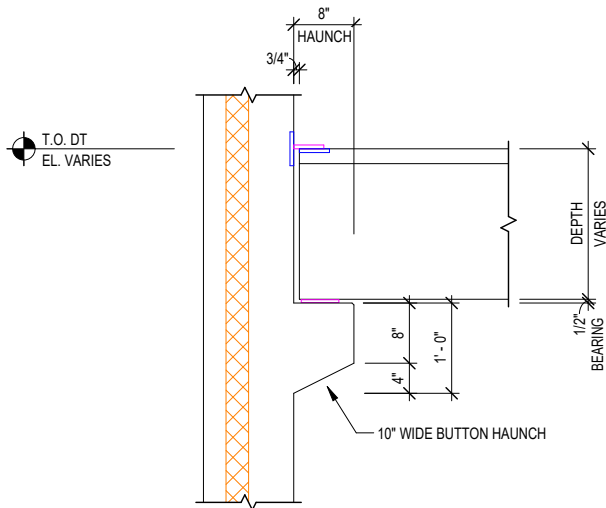

**DOUBLE TEE BEARING AT WALL POCKET**

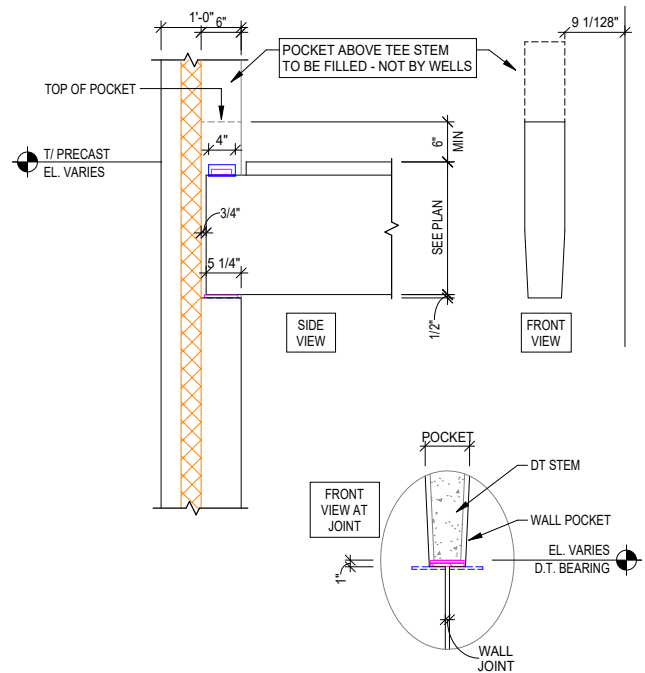

# Recommended Connection Details

## DOUBLE TEE FLANGE TO FLANGE CONNECTION

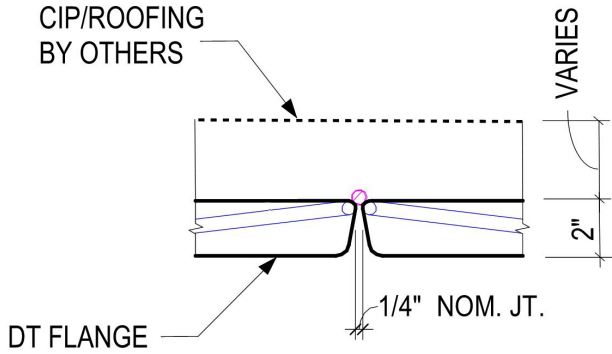

## DOUBLE TEE FLANGE TO WALL SLIP

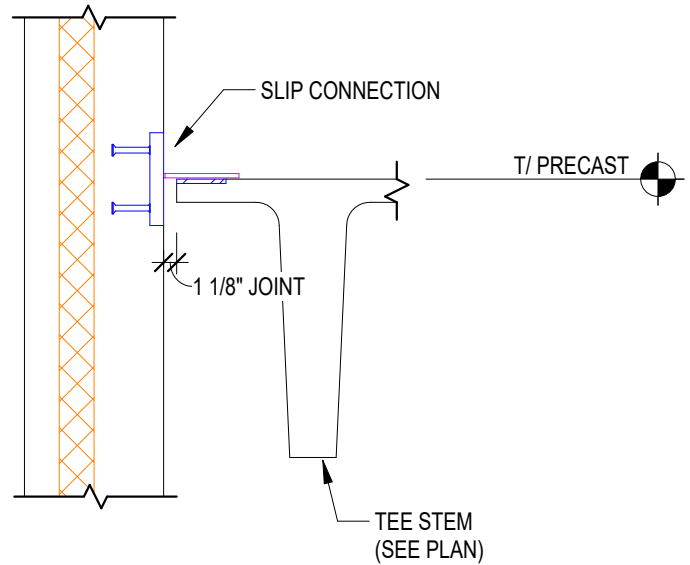

## FLANGE TO CMU SLIP

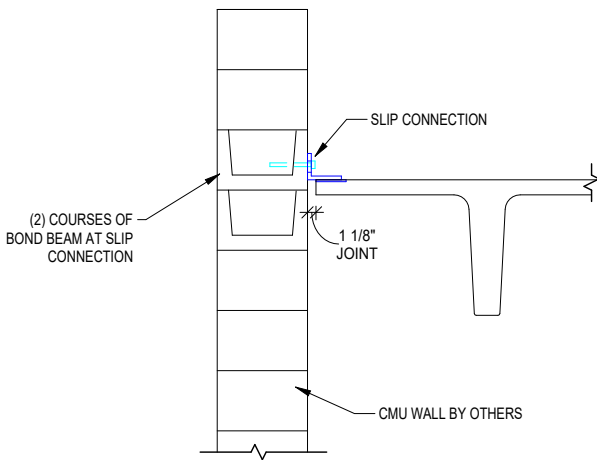

## FLANGE TO WALL

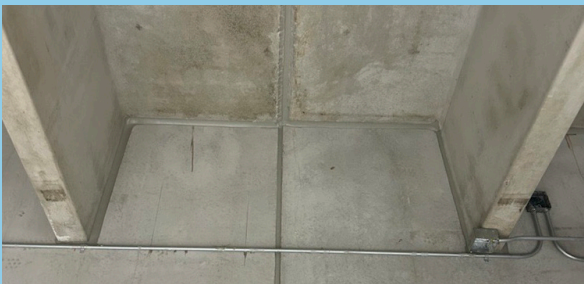
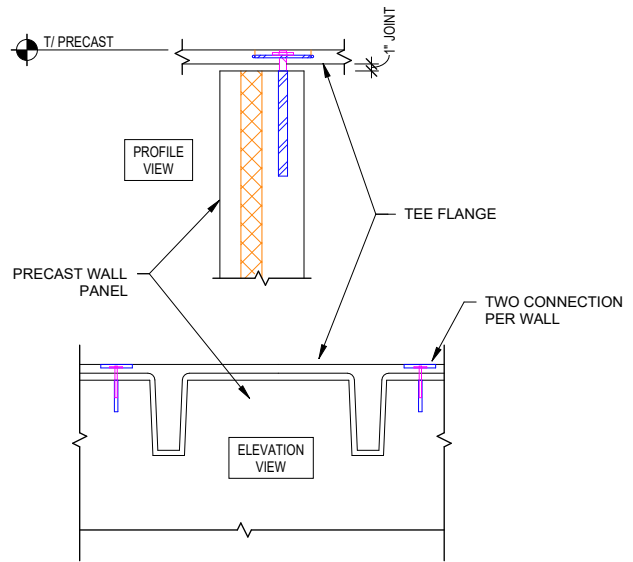

## SEALANTS

Properly sealing and maintaining double tee joints is important to creating an overall structure that will last. Caulking between joints and pockets can be provided to mitigate undesirable moisture infiltration.

# Recommended Connection of Other Material

---

## UNISTRUT

It is common to utilize Unistrut in the bottom of double tee stems. They can be used for ceiling support grids, piping, conduit, partition walls and many other applications. The unistrut is coordinated and can be cast in to the tee stem during the production process.



---

## ELECTRICAL BLOCK-OUTS

Standard sizes exist for electrical blockouts that are cast into double tee stems. They are useful for routing conduit below the bottom surface of the deck.

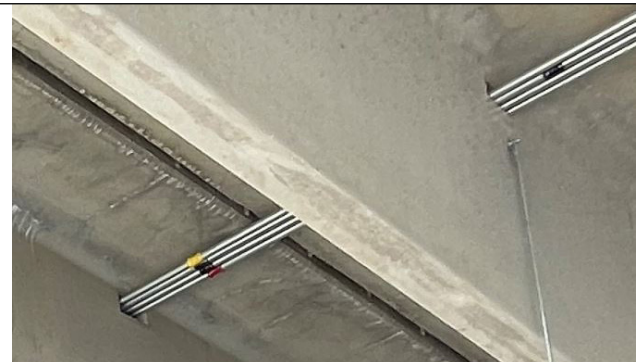

---

## PIPE SLEEVES

Mechanical coordination is a very important aspect of the coordination process for a project. Piping can be easily attached to the underside of the deck with expansion anchors.

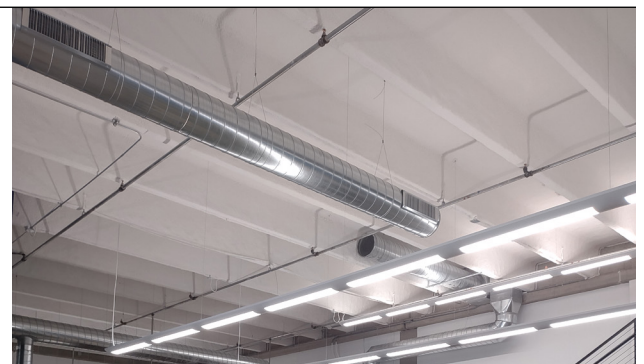

---

## EXPANSION ANCHORS AND CONCRETE SCREWS

The anchors themselves are custom to the customers needs and loading considerations. We recommend that if heavier loading is required that a steel embed plate be utilized.





North Suburban Medical Center Heliport  
 Thornton, CO  
 System: Architectural, Structural



Left + Right: Leetsdale Garage  
 Denver, CO  
 System: Architectural, Structural



**ADVANTAGES OF DOUBLE TEES OVER STEEL ROOF SYSTEMS**

**Clean Ceilings**

The ledge-free surfaces of a double tee ceiling avoid the build-up of dust and debris present with steel ceiling structures, resulting in a cleaner aesthetic over the project's lifetime and better air quality for occupants.

**Lower Profile**

Double tees can achieve half the depth of steel ceiling structures on long spans, providing more clearance for the ability to integrate electrical ductwork.

**Firewall Cost Savings**

When designing a building as a total precast system, the use of double tees reduces the need for firewalls, saving projects time and money.

**BUILD  
WITHOUT  
LIMITS™**



800.658.7049

GET INSPIRED AT **WELLS.BUILD**